

Contrast Enhancement of Gray Image Using Proposed Mask in Discrete Cosine Transform Domain

Nivedita V .Deshmukh (Hippalgaonkar)¹ ,Co-Author :Dr. Mrs.S.D.Apte²

¹RSCOE, TATHWADE,PUNE,
²Guide RSCOE, TATHWADE,PUNE

ABSTRACT: In this paper a new method for contrast enhancement based on the discrete cosine transform is discussed and implemented. The technique converts the image into DCT domain and the DCT coefficients are modified using proposed mask then the enhanced image is reconstructed using inverse DCT. The discrete cosine transform outperforms with better image quality and highest PSNR value for noiseless gray images. We compare this approach with enhancement based on the discrete wavelet transform.

Keywords: Discrete cosine transform, Discrete wavelet transform.

I. INTRODUCTION

Image Contrast Enhancement process plays an important role in enhancing image quality in which features are hardly detectable by eye. It improves the visualization of features. Basically contrast is developed due to luminance reflected by two surfaces. In satellite, medical field the contrast enhancement techniques are capable to enhance the images brightness and contrast. Histogram equalization is one the most well-known method for contrast enhancement. Such an approach generally useful for images with poor intensity distribution. By enhancing edges in image enhances the contrast. Multi scale edge enhancement approach, takes all resolution levels into account MSR softens the strongest edges and keeps the faint edges almost untouched. The strategies are different, but methods allow the user to see details which were hardly distinguishable in the original image, by reducing the ratio of strong features to faint features. The wavelet approach consists of first transforming the image using the dyadic wavelet transform. Then the two wavelet coefficients relative to the horizontal and vertical wavelet bands are modified by multiplying by constant at scale and at pixel position. Finally, the enhanced image is obtained by the inverse wavelet transform from the modified wavelet coefficients. Wavelet bases present some limitations, because they are not well adapted to the detection of highly anisotropic elements, such as alignments in an image, or sheets in a cube. In DCT approach by modifying DCT coefficients of sub images can enhance the image properly.

1.1 Overview of DWT and DCT

In this paper, discrete cosine transform for enhancing the gray image has been proposed and compared with discrete wavelet transform.

1.1.1 Discrete Wavelet Transform

The wavelet approach consists of first transforming the image the two wavelet coefficients relative to the horizontal and vertical wavelet bands are modified by multiplying by constant at scale and at pixel position. Finally the enhanced image is obtained by the inverse wavelet transform from the modified wavelet coefficients. The discrete wavelet transform is based on sub band coding and easy to implement. After transforming, an image is separated into approximations and detail coefficients. Approximate coefficients are high scale, low frequency components of an image. The detail coefficients are low scale,high frequency components. Two-dimensional DWT leads to a decomposition of approximation coefficients at level j in four components: the approximation at level $j + 1$, and the details in three orientations (horizontal, vertical, and diagonal).The following chart describes the basic decomposition steps for images:

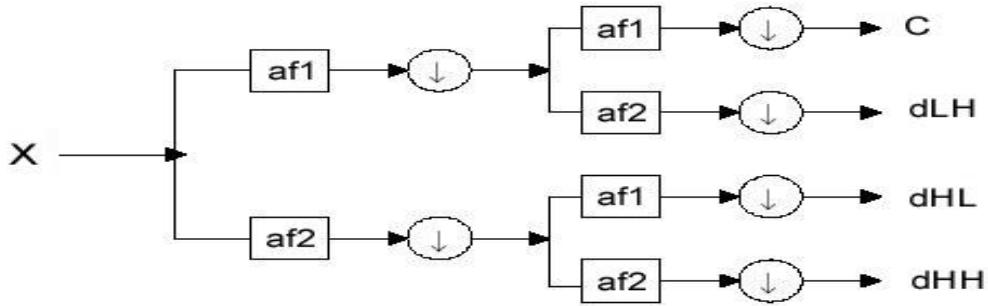

Figure 1: Decomposition of image

After decomposition approximate and detail coefficients are modified using properly designed scaling factor. Then using inverse transform enhanced image is reconstructed.

1.1.2 Discrete Cosine Transform

The DCT helps to separate the image into parts (or spectral sub-bands) of differing importance (with respect to the image's visual quality). As shown in Fig. The popular block-based DCT transform segments an image non overlapping block and applies DCT to each block. It gives result in three frequency sub-bands: low frequency sub-band, mid-frequency sub-band and high frequency sub-band. DCT based enhancement is based on two facts. The first fact is that much of the signal energy lies at low-frequencies sub-band which contains the most important visual parts of the image. The second fact is that high frequency components of the image and it is noise.

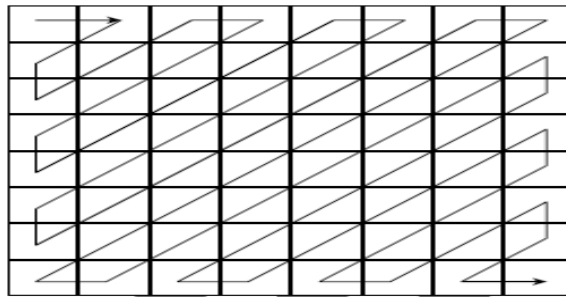

Figure 2: zigzag ordering of DCT coefficients

m	m	m	m	m	m	m	m
m	m	m	m	m	m	m	n
m	m	m	m	m	m	n	n
m	m	m	m	m	n	n	n
m	m	m	m	n	n	n	n
m	m	m	n	n	n	n	0
m	m	n	n	n	n	0	0
m	n	n	n	n	0	0	0

Figure 3: DCT 8x8 scaling mask

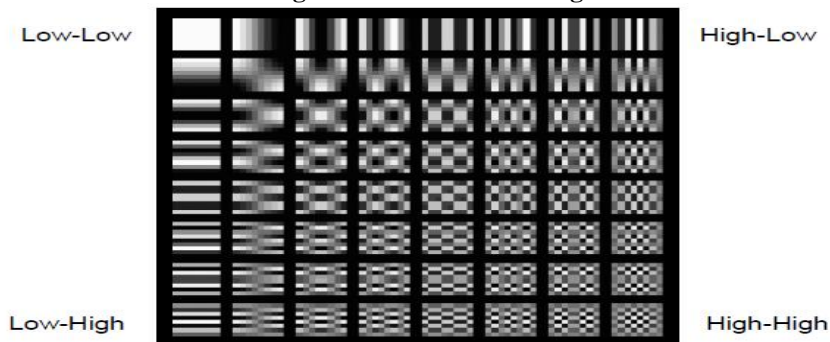

Figure 4: DCT Coefficients

II. PROPOSED METHODOLOGY

In this paper, a mask has been proposed based on discrete cosine transform and discrete wavelet transform and compared for enhancing the contrast of gray images. Discrete cosine transform is applied to extract the features of an image. The DCT converts the spatial domain into frequency domain represented by its DCT coefficients. DCT coefficients are separated in higher, mid and lower frequency components. The low frequency DCT coefficients consists important information. Hence low and high frequency coefficients are modified by modifying DCT coefficients by multiplying proper scaling factor, a new enhanced gray image is obtained. For obtaining enhanced image from modified coefficients inverse DCT is used. Assume A is a gray image, A' is an enhanced image.

The following are the steps for proposed technique.

- Step1: Read a gray image A.
- Step2: Divide the input image into 8*8 non-overlapping sub blocks.
- Step3: Apply DCT to each sub block.
- Step4: Using designed mask each sub block DCT coefficients are modified.
- Step5: By applying inverse DCT reconstruct the enhanced image A' from modified DCT coefficients.

III. RESULTS AND DISCUSSION

For obtaining better result different scaling factors are analyzed and best scaling factors are used to enhance the image.



Figure 5 Discrete Cosine Transform o/p
Table 1: DCT scaling factor analysis

Sr.no.	Lena.jpg		Scaling Factor		For noiseless image		For noisy image	
	m	n	PSNR	Contrast	PSNR	Contrast		
1	0.7000	0.8040	24.1805	0.1660	24.3919	0.7229		
2	0.8000	0.8080	24.5534	0.2025	24.7919	0.8022		
3	0.9000	0.8120	26.2177	0.2406	26.5022	0.8911		
4	1.0000	0.8160	51.6302	0.2937	33.6584	1.0030		
5	1.1000	0.8200	75.4320	0.3304	42.0890	1.1002		
6	1.2000	0.8240	93.2853	0.3595	47.9023	1.1794		
7	1.3000	0.8280	Inf	0.3829	51.9566	1.2449		



Figure 6: Discrete Wavelet Transform o/p

LL × m	LH × n
HL × p	HH × q

Figure 7: DWT scaling factor mask

Table 2: DWT scaling factor analysis

Lena.jpg Sr. no.	Scaling Factor				For noiseless image	
	m	n	P	q	PSNR	Contrast
1	1.0100	0.7080	1.0100	0.0100	43.1187	0.2856
2	1.0200	0.7160	1.0200	0.0200	44.4010	0.2915
3	1.0300	0.7240	1.0300	0.0300	45.6292	0.2954
4	1.0400	0.7320	1.0400	0.0400	46.8408	0.2987
5	1.0500	0.7400	1.0500	0.0500	48.0922	0.3025
6	1.0600	0.7480	1.0600	0.0600	49.3582	0.3052
7	1.0700	0.7560	1.0700	0.0700	50.6504	0.3095
8	1.0800	0.7640	1.0800	0.0800	52.0282	0.3114
9	1.0900	0.7720	1.0900	0.0900	53.4572	0.3150
10	1.1000	0.7800	1.1000	0.1000	54.9756	0.3216
11	1.1100	0.7880	1.1100	0.1100	56.5583	0.3279
12	1.1200	0.7960	1.1200	0.1200	58.2372	0.3338
13	1.1300	0.8040	1.1300	0.1300	59.9137	0.3384
14	1.1400	0.8120	1.1400	0.1400	61.7487	0.3398
15	1.1500	0.8200	1.1500	0.1500	63.6949	0.3403
16	1.1600	0.8280	1.1600	0.1600	65.5842	0.3431
17	1.1700	0.8360	1.1700	0.1700	65.7610	0.3440
18	1.1800	0.8440	1.1800	0.1800	69.5470	0.3453
19	1.1900	0.8520	1.1900	0.1900	71.3960	0.3466
20	1.2000	0.8600	1.2000	0.2000	73.7188	0.3499

IV. VISUAL EVALUATION

Ten respondents were asked to select the images which were of the best quality according to them. From the score table it is inferred that discrete cosine transform technique is the best for enhancing noiseless gray images

Table 3: Visual Evaluation Score table

Sr.No.	Image Type	Visual Tester	
		DCT	DWT
1	Banglo.gif	6	4
2	Lenaface.gif	9	6
3	Barbara.jpg	6	7
4	Scene.gif	7	5
5	Chest.tiff	7	5
6	Moon.tiff	7	6
7	Scene1.gif	8	6
8	Mri1.tiff	6	5
9	Bird.gif	8	6
10	Ship.gif	8	6
11	Aeroplane.gif	8	5
Total Score out of 110		80	61

Some other results are as below:



Figure 7: Discrete Cosine Transform

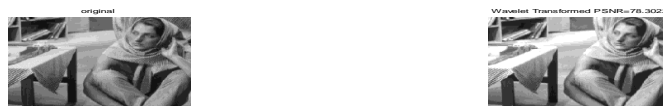

Figure 8: Discrete Wavelet Transform o/p



Figure 9: Discrete Cosine Transform



Figure 10: Discrete Wavelet Transform o/p

From above results we conclude that for enhancement of gray image discrete cosine transform outperforms better than discrete wavelet transform. Using discrete cosine transform obtained highest PSNR value is 93 dB. The image quality is better than discrete wavelet transform.

REFERENCES

- [1]. IEEE image processing 2001; 10 (3):367-82.Transform-based image enhancement algorithms with performance measure by Agaian s s, Panetta K, Grigoryan AM.
- [2]. The 2nd International Conference From Scientific Computing to Computational Engineering 2nd IC-SCCE Athens, 5-8 July, 2006 Madoukas Theodore1, Athanasiadis Emmanouil2, Bougioukos Panagiotis2, Kalatzis Ioannis1, Dimitropoulos Nikos3 and Cavouras Dionisis1, “Performance Evaluation of A-trous Wavelet based Filters for enhancing Digital Mammography Images”.
- [3]. The International Journal of Computer Applications (0975 – 8887) Volume 35– No.7, December 2011 a paper was published on “Satellite Image Contrast Enhancement using Multiwavelets and Singular Value Decomposition (SVD)”.
- [4]. The World Academy of Science, Engineering and Technology 79, 2011, “Enhancement of Low Contrast Satellite Images using Discrete Cosine Transform and Singular Value Decomposition “by A. K. Bhandari, A. Kumar and P. K. Padhy.
- [5]. The International Journal of Computer Applications (0975 – 8887) Volume 35– No.7, December 2011 a paper was presented by Sulochana S and Vidhya R on Satellite Image Contrast Enhancement using Multiwavelets and Singular Value Decomposition (SVD).
- [6]. The Optica Applicata, Vol. XLI, No. 1, 2011 “ Comparison of wavelet, Gabor and curvelet transform for face recognition” by Jtulong Zhang, Yinghui Wang, Zhyui Zhang, Chunli Xia Computer Science and Engineering School, Xian University of Technology, Xi'an, 710048, P.R. China.